



Reference: Sailplane model
H 301 and H 301 Libelle, German Data Sheet No. 251, from Serial No. 2 and on, however, Serial No. 2 to 85 only, if the elevator actuator bracket has welded assembly guides instead of screwed guides.
Standard Libelle and
Standard Libelle 201 B, German Data Sheet No. 251, all Serial Numbers,
Club Libelle 205, German Data Sheet Nr. 304, up to Serial Number 107,
Hornet, up to Serial Number 3

Subject: Reinforcement of the elevator assembly guides.

Reason: Careless assembly of the tailplane caused damaged elevator assembly guides, resulting in a possible improper assembly of the tailplane and loss of elevator control.

Urgency: Method 1 and 2: before the next flight
Method 3: before February 29th, 1976

Method:

1. With a 5 x powered magnifier visually inspect the assembly guides for distortion, bending and/or for cracks in the welded seam.
2. If damage is found replace the bracket immediately with a bracket to be reinforced according to method 4.
3. If no damage is found replace the bracket with a bracket to be reinforced according to method 4 before the date quoted in "Urgency".
4. Weld in two sheet metal strips according to the following drawings to reinforce both guides. (see next page)

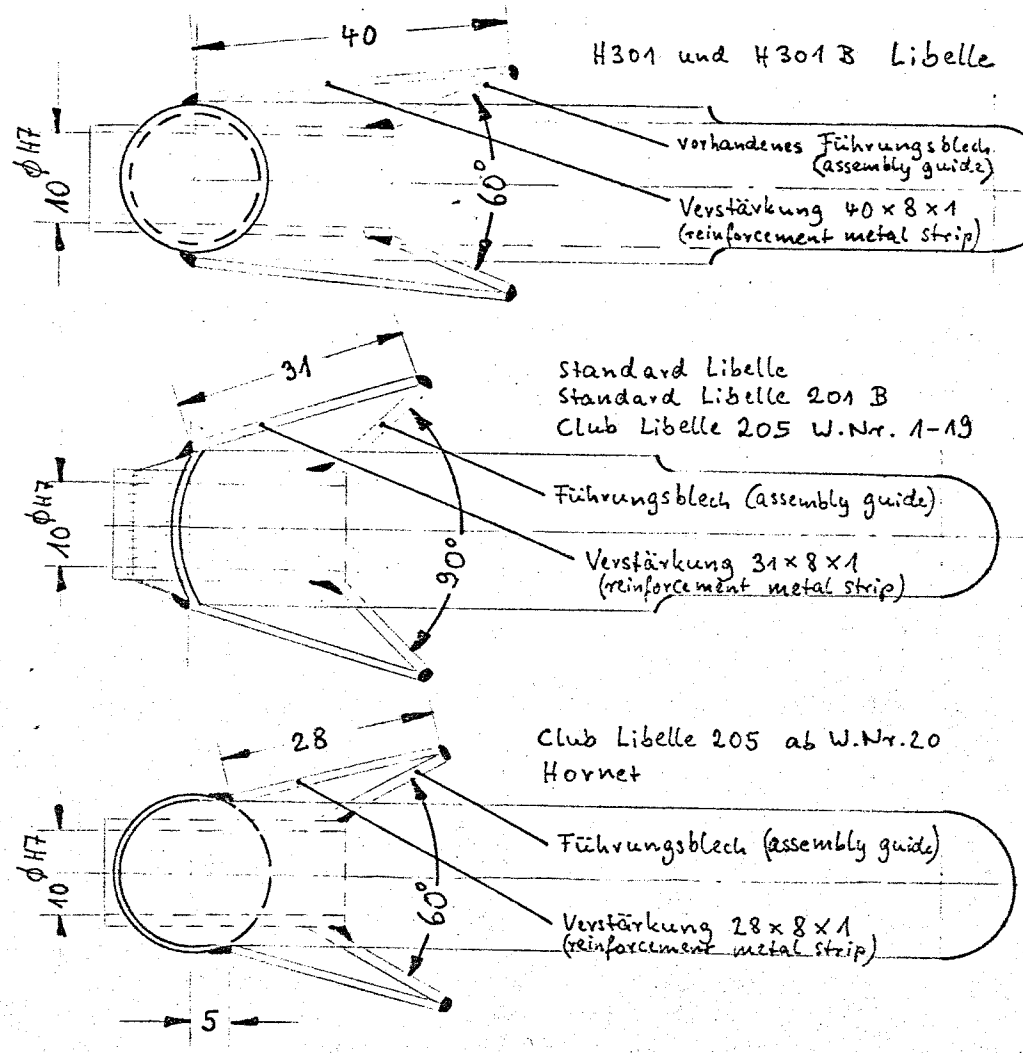

Material and Processing:

Sheet metal to specification 1.7214.4 or 1.7734.4, welding material to specification 1.7734.2 or 1.7324.0, welding process WIG (Wolfram-Inert-Gas). After removing the bracket insert a pin 10 mm ϕ into the tube instead of the actuator pin to prevent warping during welding. It should be possible to insert this pin simply by hand. Remove the pin after the bracket has cooled down. Preserve the bracket again (recommended single component primer B 1742 from Lackfabrik Bäder and nitro lacquer). Fit the bracket to the tailplane and pay attention to the 2 washers between bracket and ball bearings.

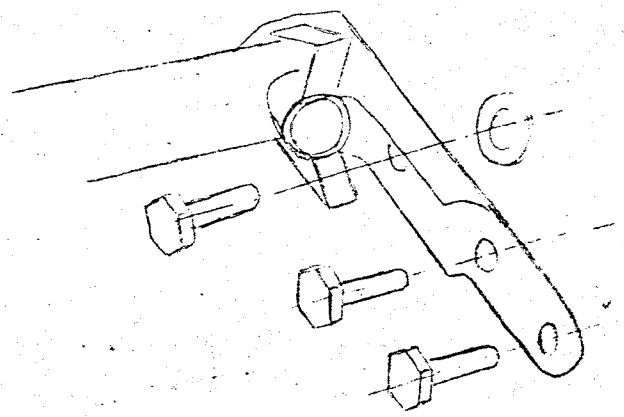



Center of gravity: no change

Weight: no change

Accomplishment and Certifying: Method 1, 2 and 3 may be carried out by an experienced person; the correct accomplishment has to be certified in the aircraft log book by the person in charge of the aircraft or by a licensed inspector.

Method 4 has to be carried out by Glasflügel or a licensed repair shop.

Remarks:

1. This Technical Note is standard on the model "Club Libelle 205" from Serial No. 108 and on and for the model "Hornet" from Serial No. 4 and on.
2. After rigging always remember to check for proper function and full movement of stick and elevator.

GLASFLÜGEL
Ing. E. Hänle KG
July 11th, 1975